

Finishing Spec Core

Catalog No. **TSF-8040-34-14-09-0022**

341409 E

Rev Level **A**

Picture

1ST ISSUED

Customer	Customer Part #

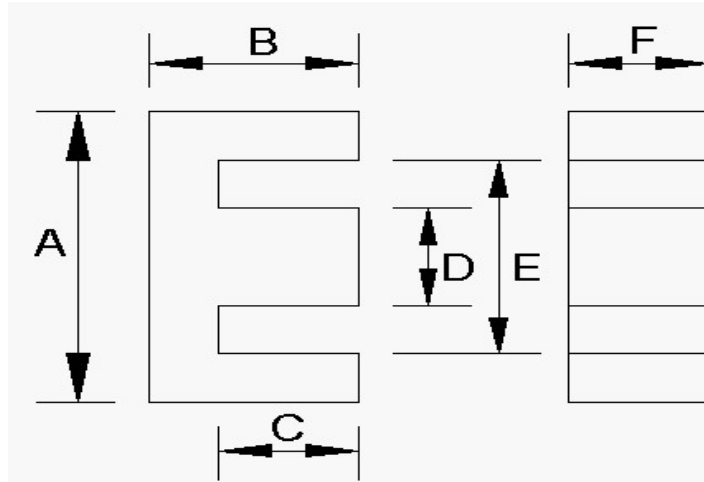

GRIND SPECS

	B	C	BW	GRIND BACKWALL	GRIND MATING SURFACE	GAP DEPTH	AL VALUE	L CONTROL LIMIT
	inches	inches	inches			inches	nH/T^2	mH
Maximum	0.5610	0.3930		NO	YES	0.0330		#VALUE!
Nominal	0.5560	0.3850				0.0300		
Minimum	0.5510	0.3770				0.0270		#VALUE!

APPROVED FOR PRODUCTION _____ DATE _____

Inductance (AL) Test Conditions mate with							
Critical Spec. Al or Mech.	Tolerance %	1 or 2 core GAP	Coil #	# Turns	Test Frequency kHz	Test Voltage Vrms	Test Flux Density Gauss
MECH	0.3%	EACH					

Comments

Dimensions:	A	D	E	F	G	H	J	COLOR CODE
Maximum	1.351	0.374	1.045	0.374				RED
Nominal	1.351	0.367	1.025	0.367				
Minimum	1.378	0.360	1.005	0.360				
