

Finishing Spec Core

Catalog No. **TSF-8040-25-10-13-0005**

251013

E

Rev Level **A**

Picture

1ST ISSUED

Customer	Customer Part #

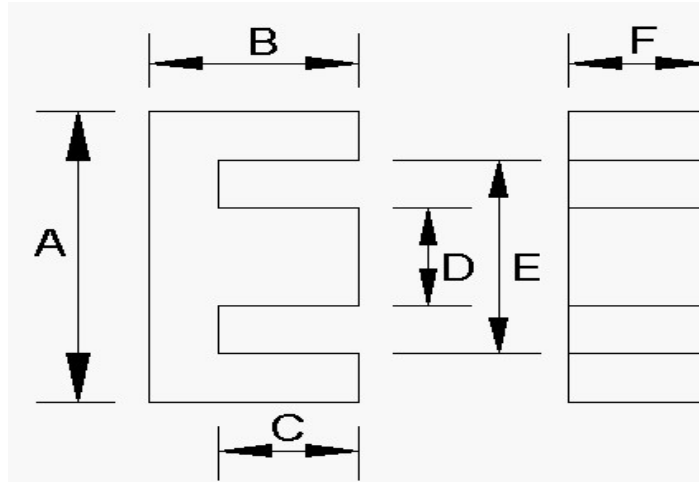

GRIND SPECS

	B	C	BW	GRIND BACKWALL	GRIND MATING SURFACE	GAP DEPTH	AL VALUE	L CONTROL LIMIT
	inches	inches	inches			inches	nH/T^2	mH
Maximum	0.3850	0.2650		NO	YES	0.0104	246.10	2.3805
Nominal	0.3800	0.2600					230.00	2.3000
Minimum	0.3750	0.2550					213.90	2.2195

APPROVED FOR PRODUCTION _____ DATE _____

Inductance (AL) Test Conditions mate with							
Critical Spec. Al or Mech.	Tolerance %	1 or 2 core GAP	Coil #	# Turns	Test Frequency	Test Voltage	Test Flux Density
					kHz	Vrms	Gauss
AL	7.0%	TWO		100.0	10.0	0.175	5

Comments

Dimensions:	A	D	E	F	G	H	J	COLOR CODE
	inches	inches	inches	inches	inches	inches	inches	
Maximum	1.000	0.255	0.772	0.510				
Nominal	1.000	0.250	0.757	0.500				
Minimum	1.020	0.245	0.742	0.490				
