

Finishing Spec Core

Catalog No. **TSF-7099-25-13-07-0006**

**251307**

**E**

Rev Level **C**

Picture

**1ST ISSUED** 2/12/2001

Customer	Customer Part #

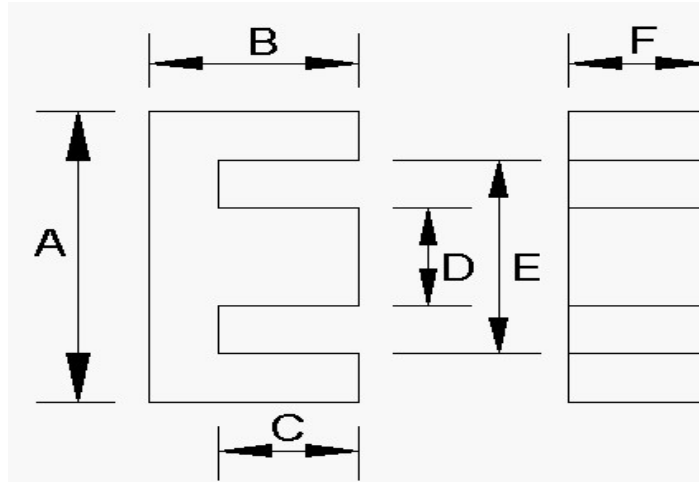

GRIND SPECS

	B	C	BW	GRIND BACKWALL	GRIND MATING SURFACE	GAP DEPTH	AL VALUE	L CONTROL LIMIT
	inches	inches	inches			inches	nH/T^2	mH
Maximum	0.5040	0.3620		NO	YES	0.0208	160.16	3.3254
Nominal	0.4940	0.3520					154.00	3.2602
Minimum	0.4840	0.3420					147.84	3.1950

APPROVED FOR PRODUCTION \_\_\_\_\_ DATE \_\_\_\_\_

Inductance (AL) Test Conditions mate with							
Critical Spec. Al or Mech.	Tolerance %	1 or 2 core GAP	Coil #	# Turns	Test Frequency	Test Voltage	Test Flux Density
					kHz	Vrms	Gauss
AL	4.0%	ONE		145.5	20.0	1.000	15

**Comments**  
**Q >250 @ 20 Khz 1.0 VRMS**

Dimensions:	A	D	E	F	G	H	J	COLOR CODE
	inches	inches	inches	inches	inches	inches	inches	
Maximum	0.986	0.295	0.723	0.295				
Nominal	0.986	0.285	0.706	0.283				
Minimum	1.006	0.275	0.689	0.271				
