

UPDATING

UPDATING

UPDATING

UPDATING

UPDATING

UPDATING

Finishing Spec Core

Catalog No. **7099-16-07-05-0004**
160705 E

Picture

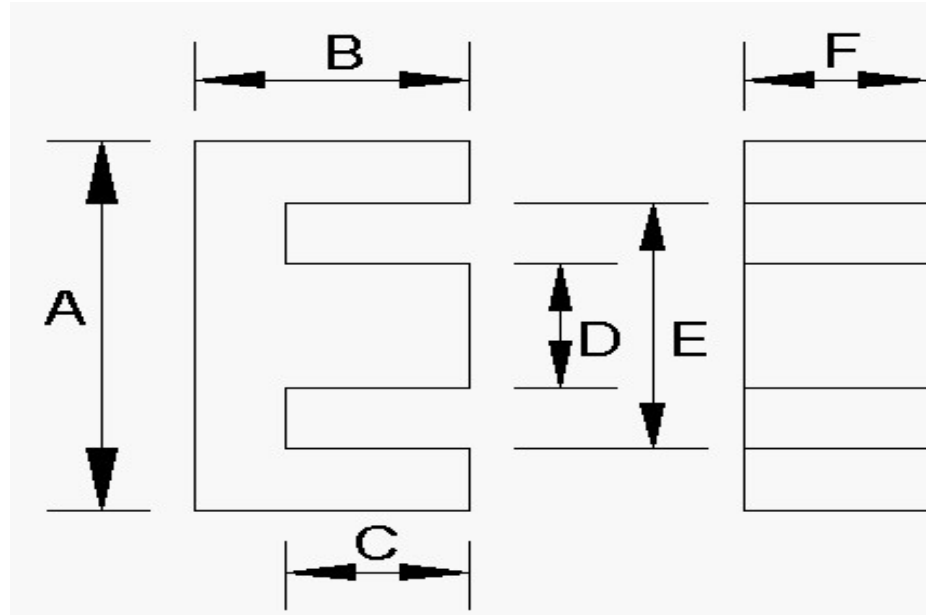

GRIND SPECS	B	C	BW	GRIND BACKWALL	GRIND MATING SURFACE	GAP DEPTH per pc. (inches)	AL VALUE	L CONTROL LIMIT
	inches	inches	inches				nH/T^2	mH
Maximum	0.2880	0.2090					53.0	0.04078
Nominal	0.2830	0.2040		NO	YES	0.0140	51.0	0.03998
Minimum	0.2780	0.1990					49.0	0.03918

Inductance (AL) Test Conditions mate with:

Critical Spec. Al or Mech.	Tolerance	1 or 2 core GAP	Coil #	# Turns	Test Frequency	Test Voltage	Test Flux Density
					kHz	Vrms	Gauss
AL	4%	TWO	920	28	10	0.100	5

Dimensions:	A	D	E	F	G	H	J	COLOR CODE
	inches	inches	inches	inches	inches	inches	inches	
Maximum	0.642	0.160	0.470	0.193				
Nominal	0.630	0.157	0.461	0.189				
Minimum	0.618	0.154	0.452	0.185				