

Finishing Spec Core

Catalog No. **TSF-7090-25-13-07-0016**

251307

E

Rev Level **B**

Picture

1ST ISSUED

Customer	Customer Part #

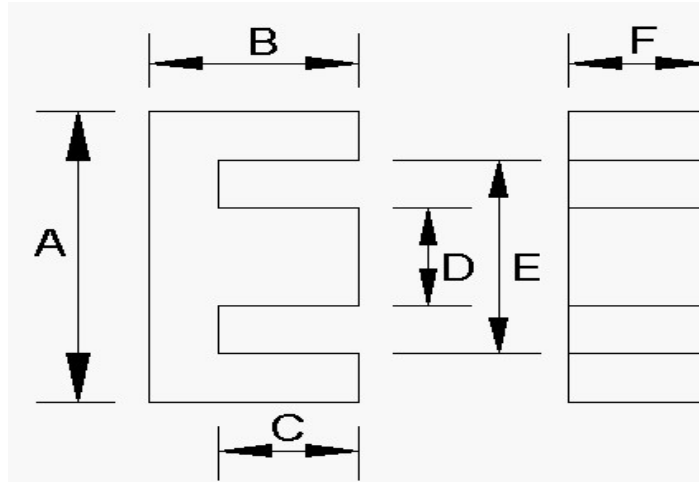

GRIND SPECS

	B	C	BW	GRIND BACKWALL	GRIND MATING SURFACE	GAP DEPTH	AL VALUE	L CONTROL LIMIT
	inches	inches	inches			inches	nH/T^2	mH
Maximum	0.5040	0.3620		NO	YES	0.0238	87.90	0.8660
Nominal	0.4940	0.3520					85.34	0.8530
Minimum	0.4840	0.3420					82.78	0.8405

APPROVED FOR PRODUCTION _____ DATE _____

Inductance (AL) Test Conditions mate with							
Critical Spec. Al or Mech.	Tolerance %	1 or 2 core GAP	Coil #	# Turns	Test Frequency	Test Voltage	Test Flux Density
					kHz	Vrms	Gauss
AL	3.0%	TWO		100.0	10.0	1.000	

Comments

Dimensions:	A	D	E	F	G	H	J	COLOR CODE
	inches	inches	inches	inches	inches	inches	inches	
Maximum	0.986	0.295	0.723	0.295				
Nominal	0.986	0.285	0.706	0.283				
Minimum	1.006	0.275	0.689	0.271				
