

UPDATING

UPDATING

UPDATING

UPDATING

UPDATING

UPDATING

**Finishing Spec Core**

Catalog No. **7070-43-21-15-0018**  
**432115 E**

Picture

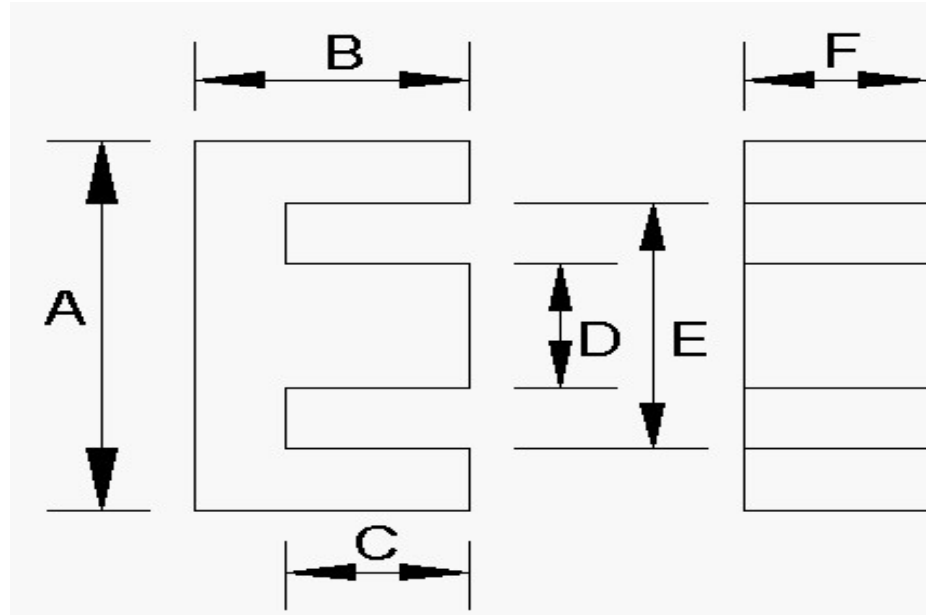

GRIND SPECS	B	C	BW	GRIND BACKWALL	GRIND MATING SURFACE	GAP DEPTH per pc. (inches)	AL VALUE nH/T^2	L CONTROL LIMIT mH
	inches	inches	inches					
Maximum	0.8360	0.6050					210.0	2.05000
Nominal	0.8310	0.5960		NO	YES	0.0290	200.0	2.00000
Minimum	0.8260	0.5870					190.0	1.95000

Inductance (AL) Test Conditions mate with:

Critical Spec. Al or Mech.	Tolerance	1 or 2 core GAP	Coil #	# Turns	Test Frequency	Test Voltage	Test Flux Density
					kHz	Vrms	Gauss
AL	5%	TWO	279	100	10	0.400	5

Dimensions:	A	D	E	F	G	H	J	COLOR CODE
	inches	inches	inches	inches	inches	inches	inches	
Maximum	1.721	0.478	1.243	0.620				
Nominal	1.687	0.468	1.219	0.608				
Minimum	1.653	0.458	1.195	0.596				