

Finishing Spec Core

Catalog No. **TSF-7070-35-35-00-0005**

353500

PQ

Rev Level **A**

Picture

1ST ISSUED 9/15/2000

Customer	Customer Part #

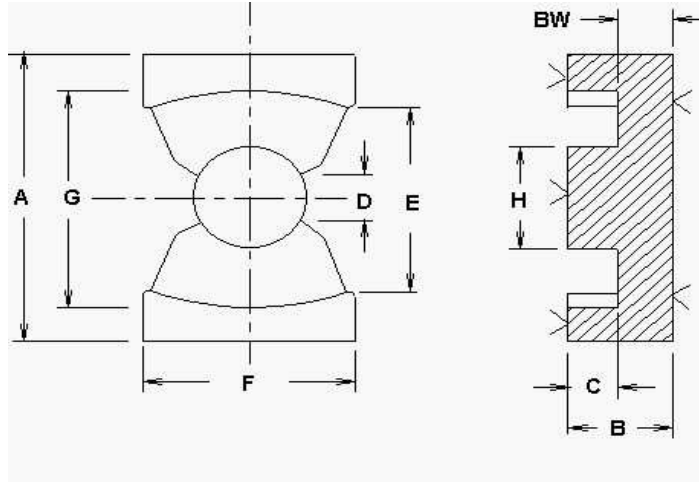

GRIND SPECS

	B	C	BW	GRIND BACKWALL	GRIND MATING SURFACE	GAP DEPTH	AL VALUE	L CONTROL LIMIT
	inches	inches	inches			inches	nH/T^2	mH
Maximum	0.6890	0.4980	0.1970	YES	YES	0.0152	328.60	3.1930
Nominal	0.6840	0.4920	0.1920				310.00	3.1000
Minimum	0.6790	0.4860	0.1870				291.40	3.0070

APPROVED FOR PRODUCTION _____ DATE _____

Inductance (AL) Test Conditions mate with							
Critical Spec. Al or Mech.	Tolerance %	1 or 2 core GAP	Coil #	# Turns	Test Frequency kHz	Test Voltage Vrms	Test Flux Density Gauss
AL	6.0%	TWO		100.0	10.0	0.435	5

Comments

Dimensions:	A	D	E	F	G	H	J	COLOR CODE
	inches	inches	inches	inches	inches	inches	inches	
Maximum	1.422			1.044	1.280	0.575		
Nominal	1.422			1.024	1.260	0.565		
Minimum	1.450	0.235	0.925	1.004	1.240	0.555		
