

UPDATING UPDATING UPDATING UPDATING UPDATING UPDATING

Finishing Spec Core

Catalog No. **7070-34-14-09-0147**

341409

E

Rev Level **A**

Picture

1ST ISSUED 8/1/2007

Customer	Customer Part #
	50770609P

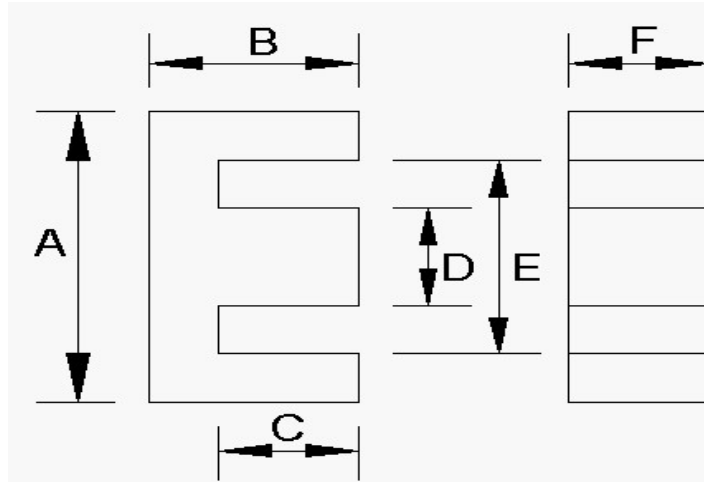

REQUIRED GRINDER BELT SPEED			
GRINDER	UPDATED	M/MIN	INCH/MIN
1	0	0.00	0.00
2	0	0.00	0.00
3	0	0.00	0.00
4	0	0.00	0.00
5	0	0.00	0.00

GRIND SPECS

	B	C	BW	GRIND BACKWALL	GRIND MATING SURFACE	GAP DEPTH per pc. (inches)	AL VALUE nH/T^2	L CONTROL LIMIT mH
	inches	inches	inches					
Maximum	0.5610	0.3930					61.8	0.02436
Nominal	0.5560	0.3850		NO	YES	0.0689	60.0	0.02400
Minimum	0.5510	0.3770					58.2	0.02364

L @ DC 1	L @ DC 2
mH min	mH min
ADC (AMPS)	ADC (AMPS)

Inductance (AL) Test Conditions mate with:								Grinding PCS/HR
Critical Spec. Al or Mech.	Tolerance	1 or 2 core GAP	Coil #	# Turns	Test Frequency kHz	Test Voltage Vrms	Test Flux Density Gauss	
AL	3%	TWO	338	20	100	0.360	5	

APPROVED FOR PRODUCTION _____ DATE _____

Comments								

Dimensions:	A	D	E	F	G	H	J	COLOR CODE
	inches	inches	inches	inches	inches	inches	inches	
Maximum	1.378	0.374	1.045	0.374				
Nominal	1.351	0.367	1.025	0.367				
Minimum	1.324	0.360	1.005	0.360				

Packaging Comments										
8 ROWS OF 18 SPACE BETWEEN BLOCKS										

Packaging										
Method	Die Cut	Type of Box or Bag	pcs/bag or pcs/cell or # rows per board	# columns per board	Pieces / Board	Layers	Spacer Boards	Foam	Pcs/Box	WEIGHT OF BOX APPROX
SKIN	P4400	4400C	18	8	144	6	0	4	864	30.4