

UPDATING

UPDATING

UPDATING

UPDATING

UPDATING

UPDATING

**Finishing Spec Core**

Catalog No. **7070-34-14-09-0129**

**341409**

**E**

Picture

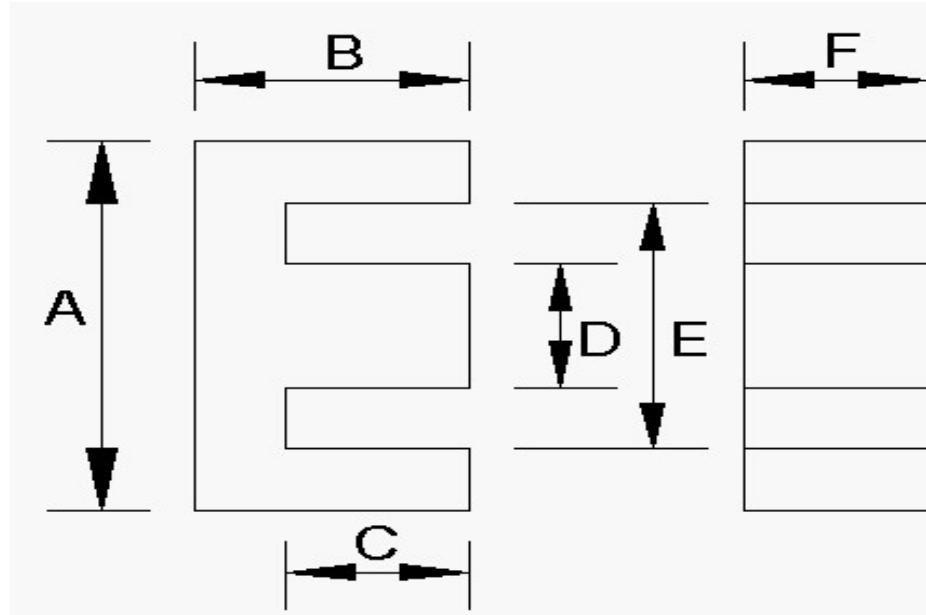

GRIND SPECS	B	C	BW	GRIND BACKWALL	GRIND MATING SURFACE	GAP DEPTH per pc. (inches)	AL VALUE	L CONTROL LIMIT
	inches	inches	inches				nH/T^2	mH
Maximum	0.5610	0.3930					69.0	0.02720
Nominal	0.5560	0.3850		NO	YES	0.0535	67.0	0.02680
Minimum	0.5510	0.3770					65.0	0.02640

Inductance (AL) Test Conditions mate with:

Critical Spec. Al or Mech.	Tolerance	1 or 2 core GAP	Coil #	# Turns	Test Frequency	Test Voltage	Test Flux Density
					kHz	Vrms	Gauss
AL	3%	TWO	338	20	100	0.360	5

Dimensions:	A	D	E	F	G	H	J	COLOR CODE
	inches	inches	inches	inches	inches	inches	inches	
Maximum	1.378	0.374	1.045	0.374				
Nominal	1.351	0.367	1.025	0.367				
Minimum	1.324	0.360	1.005	0.360				