

UPDATING

UPDATING

UPDATING

UPDATING

UPDATING

UPDATING

Finishing Spec Core

Catalog No. **7070-30-15-06-0009**

301506

E

Picture

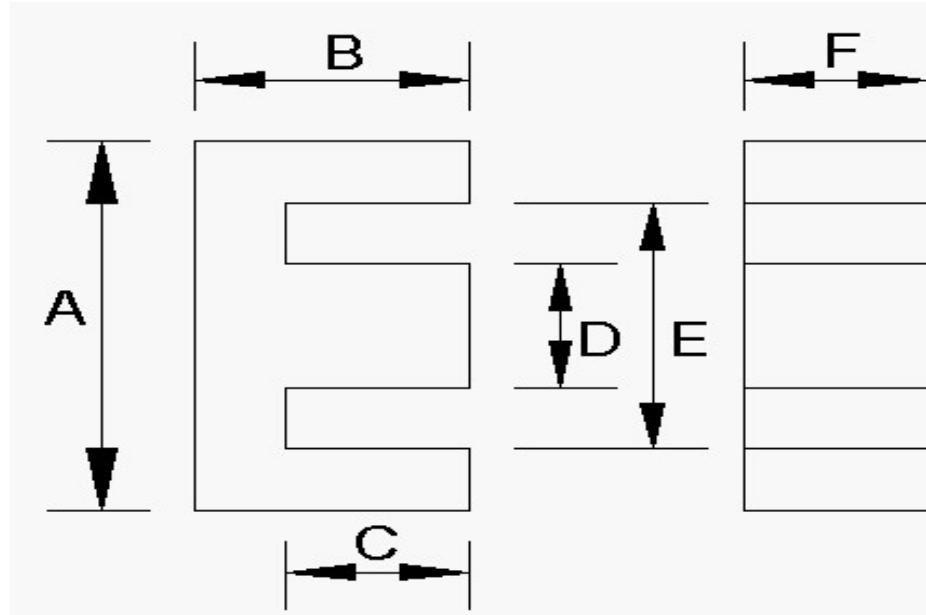

| GRIND SPECS | B | C | BW | GRIND BACKWALL | GRIND MATING SURFACE | GAP DEPTH per pc. (inches) | AL VALUE | L CONTROL LIMIT |
|-------------|--------|--------|--------|----------------|----------------------|----------------------------|----------|-----------------|
| | inches | inches | inches | | | | nH/T^2 | mH |
| Maximum | 0.6000 | 0.4110 | | | | | 334.8 | 3.22400 |
| Nominal | 0.5950 | 0.4040 | | NO | YES | 0.0090 | 310.0 | 3.10000 |
| Minimum | 0.5900 | 0.3970 | | | | | 285.2 | 2.97600 |

Inductance (AL) Test Conditions mate with:

| Critical Spec. Al or Mech. | Tolerance | 1 or 2 core GAP | Coil # | # Turns | Test Frequency | Test Voltage | Test Flux Density |
|----------------------------|-----------|-----------------|--------|---------|----------------|--------------|-------------------|
| | | | | | kHz | Vrms | Gauss |
| AL | 8% | ONE | 717 | 100 | 10 | 0.130 | 5 |

| Dimensions: | A | D | E | F | G | H | J | COLOR CODE |
|-------------|--------|--------|--------|--------|--------|--------|--------|------------|
| | inches | inches | inches | inches | inches | inches | inches | |
| Maximum | 1.205 | 0.275 | 0.808 | 0.273 | | | | |
| Nominal | 1.181 | 0.270 | 0.792 | 0.268 | | | | |
| Minimum | 1.157 | 0.265 | 0.776 | 0.263 | | | | |