

UPDATING

UPDATING

UPDATING

UPDATING

UPDATING

UPDATING

**Finishing Spec Core**

Catalog No. **7070-30-15-06-0006**

**301506**

**E**

Picture

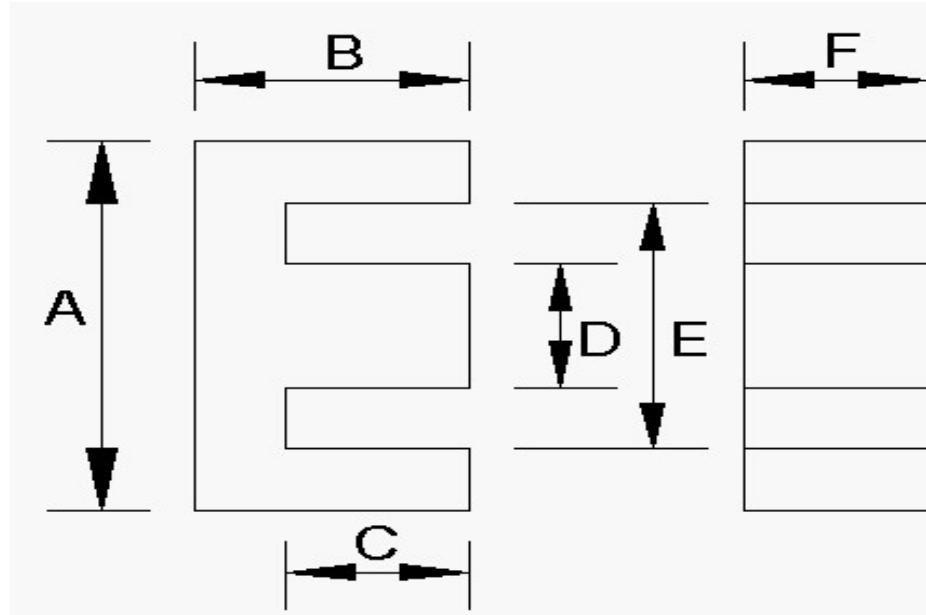

GRIND SPECS	<b>B</b>	<b>C</b>	<b>BW</b>	<b>GRIND BACKWALL</b>	<b>GRIND MATING SURFACE</b>	<b>GAP DEPTH per pc. (inches)</b>	<b>AL VALUE</b>	<b>L CONTROL LIMIT</b>
	<b>inches</b>	<b>inches</b>	<b>inches</b>				<b>nH/T^2</b>	<b>mH</b>
Maximum	0.6000	0.4110		NO	YES	0.0230	82.4	0.81200
Nominal	0.5950	0.4040					77.6	0.80000
Minimum	0.5900	0.3970					77.6	0.78800

Inductance (AL) Test Conditions mate with:

<b>Critical Spec. Al or Mech.</b>	<b>Tolerance</b>	<b>1 or 2 core GAP</b>	<b>Coil #</b>	<b># Turns</b>	<b>Test Frequency</b>	<b>Test Voltage</b>	<b>Test Flux Density</b>
					<b>kHz</b>	<b>Vrms</b>	<b>Gauss</b>
AL	3%	TWO	717	100	10	0.130	5

<b>Dimensions:</b>	<b>A</b>	<b>D</b>	<b>E</b>	<b>F</b>	<b>G</b>	<b>H</b>	<b>J</b>	<b>COLOR CODE</b>
	<b>inches</b>	<b>inches</b>	<b>inches</b>	<b>inches</b>	<b>inches</b>	<b>inches</b>	<b>inches</b>	
Maximum	1.205	0.275	0.808	0.273				
Nominal	1.181	0.270	0.792	0.268				
Minimum	1.157	0.265	0.776	0.263				