

UPDATING    UPDATING    UPDATING    UPDATING    UPDATING    UPDATING

**Finishing Spec Core**

Catalog No. **7070-25-13-07-0048**  
**251307**      **E**

Picture

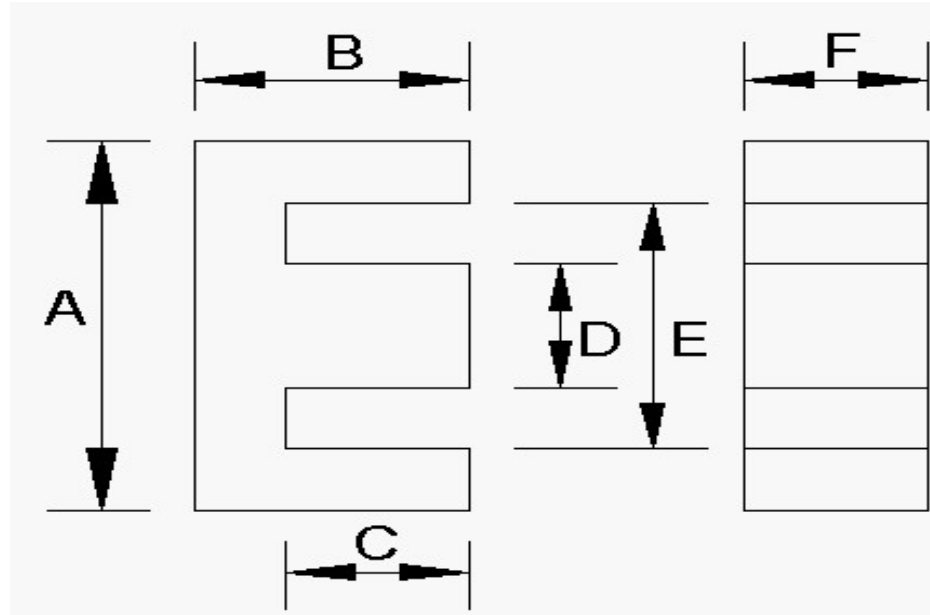

GRIND SPECS	B	C	BW	GRIND BACKWALL	GRIND MATING SURFACE	GAP DEPTH per pc. (inches)	AL VALUE nH/T^2	L CONTROL LIMIT mH
	inches	inches	inches					
Maximum	0.4990	0.3600					160.5	1.55250
Nominal	0.4940	0.3520		NO	YES	0.0108	150.0	1.50000
Minimum	0.4889	0.3440					139.5	1.44750

Inductance (AL) Test Conditions mate with:

Critical Spec. Al or Mech.	Tolerance	1 or 2 core GAP	Coil #	# Turns	Test Frequency	Test Voltage	Test Flux Density
					kHz	Vrms	Gauss
AL	7%	TWO	956	100	10	0.120	5

Dimensions:	A	D	E	F	G	H	J	COLOR CODE
	inches	inches	inches	inches	inches	inches	inches	
Maximum	1.006	0.291	0.720	0.289				
Nominal	0.986	0.285	0.706	0.283				
Minimum	0.966	0.279	0.692	0.278				