

UPDATING

UPDATING

UPDATING

UPDATING

UPDATING

UPDATING

Finishing Spec Core

Catalog No. **7070-25-10-06-0124**
251006 E

Picture

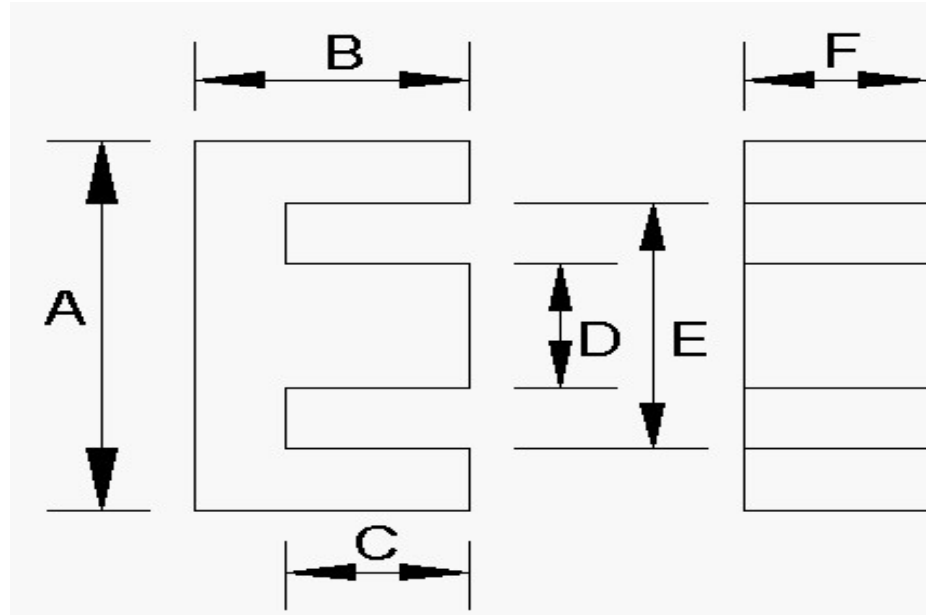

GRIND SPECS	B	C	BW	GRIND BACKWALL	GRIND MATING SURFACE	GAP DEPTH per pc. (inches)	AL VALUE	L CONTROL LIMIT
	inches	inches	inches				nH/T^2	mH
Maximum	0.3850	0.2650				0.0418	76.5	2.13797
Nominal	0.3800	0.2600		NO	YES		75.0	2.11680
Minimum	0.3750	0.2550					73.5	2.09563

Inductance (AL) Test Conditions mate with: **7070 25-16-06-0000**

Critical Spec. Al or Mech.	Tolerance	1 or 2 core GAP	Coil #	# Turns	Test Frequency	Test Voltage	Test Flux Density
					kHz	Vrms	Gauss
AL	2%	ONE	606	168	1	0.100	34

Dimensions:	A	D	E	F	G	H	J	COLOR CODE
	inches	inches	inches	inches	inches	inches	inches	
Maximum	1.020	0.255	0.772	0.255				
Nominal	1.000	0.250	0.757	0.250				
Minimum	0.980	0.245	0.742	0.245				