

UPDATING

UPDATING

UPDATING

UPDATING

UPDATING

UPDATING

**Finishing Spec Core**

Catalog No. **7070-25-10-06-0123**  
**251006 E**

Picture

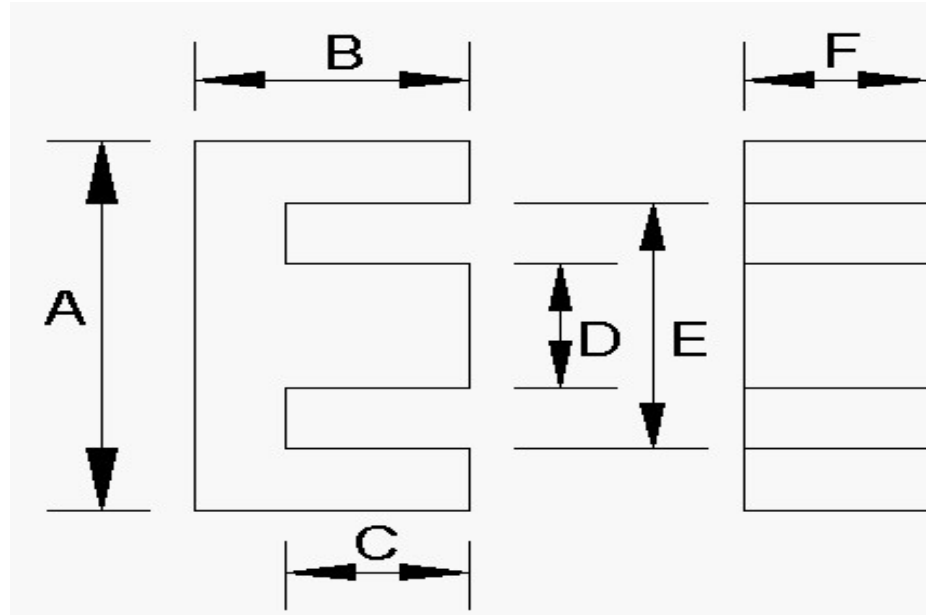

GRIND SPECS	B	C	BW	GRIND BACKWALL	GRIND MATING SURFACE	GAP DEPTH per pc. (inches)	AL VALUE nH/T^2	L CONTROL LIMIT mH
	inches	inches	inches					
Maximum	0.3850	0.2650					105.0	0.04100
Nominal	0.3800	0.2600		NO	YES	0.0272	100.0	0.04000
Minimum	0.3750	0.2550					95.0	0.03900

Inductance (AL) Test Conditions mate with:

Critical Spec. Al or Mech.	Tolerance	1 or 2 core GAP	Coil #	# Turns	Test Frequency	Test Voltage	Test Flux Density
					kHz	Vrms	Gauss
AL	5%	ONE	257	20	100	0.180	5

Dimensions:	A	D	E	F	G	H	J	COLOR CODE
	inches	inches	inches	inches	inches	inches	inches	
Maximum	1.020	0.255	0.772	0.255				
Nominal	1.000	0.250	0.757	0.250				
Minimum	0.980	0.245	0.742	0.245				