

UPDATING

UPDATING

UPDATING

UPDATING

UPDATING

UPDATING

Finishing Spec Core

Catalog No. **7070-25-10-06-0113**
251006 E

Picture

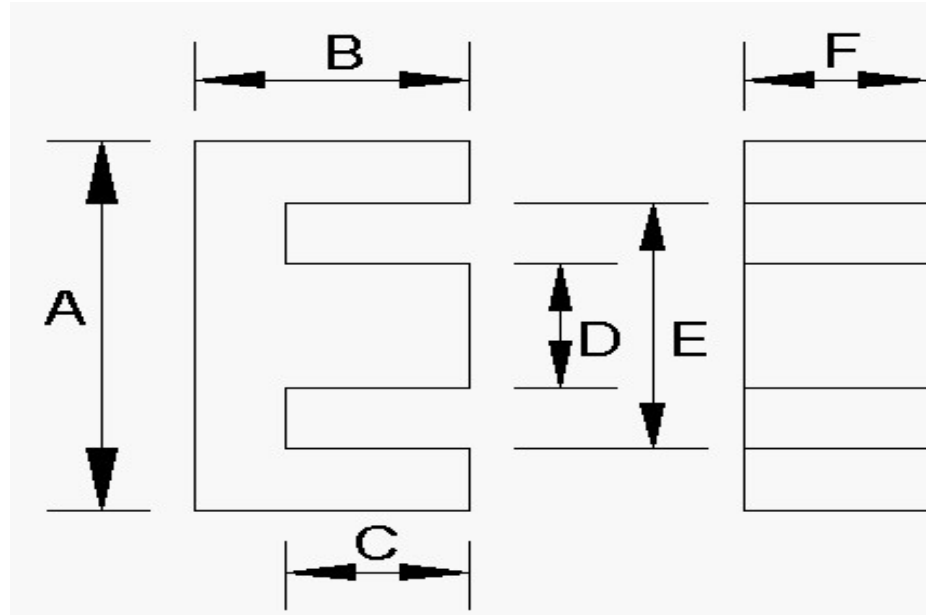

| GRIND SPECS | B | C | BW | GRIND BACKWALL | GRIND MATING SURFACE | GAP DEPTH per pc. (inches) | AL VALUE | L CONTROL LIMIT |
|-------------|--------|--------|--------|----------------|----------------------|----------------------------|----------|-----------------|
| | inches | inches | inches | | | | nH/T^2 | mH |
| Maximum | 0.3850 | 0.2650 | | | | | 149.0 | 0.05850 |
| Nominal | 0.3800 | 0.2600 | | NO | YES | 0.0172 | 142.0 | 0.05700 |
| Minimum | 0.3750 | 0.2550 | | | | | 135.0 | 0.05550 |

Inductance (AL) Test Conditions mate with:

| Critical Spec. AI or Mech. | Tolerance | 1 or 2 core GAP | Coil # | # Turns | Test Frequency | Test Voltage | Test Flux Density |
|----------------------------|-----------|-----------------|--------|---------|----------------|--------------|-------------------|
| | | | | | kHz | Vrms | Gauss |
| AL | 5% | ONE | 257 | 20 | 100 | 0.180 | 5 |

| Dimensions: | A | D | E | F | G | H | J | COLOR CODE |
|-------------|--------|--------|--------|--------|--------|--------|--------|------------|
| | inches | inches | inches | inches | inches | inches | inches | |
| Maximum | 1.020 | 0.255 | 0.772 | 0.255 | | | | |
| Nominal | 1.000 | 0.250 | 0.757 | 0.250 | | | | |
| Minimum | 0.980 | 0.245 | 0.742 | 0.245 | | | | |