

UPDATING

UPDATING

UPDATING

UPDATING

UPDATING

UPDATING

Finishing Spec Core

Catalog No. **7070-20-10-05-0013**
201005 E

Picture

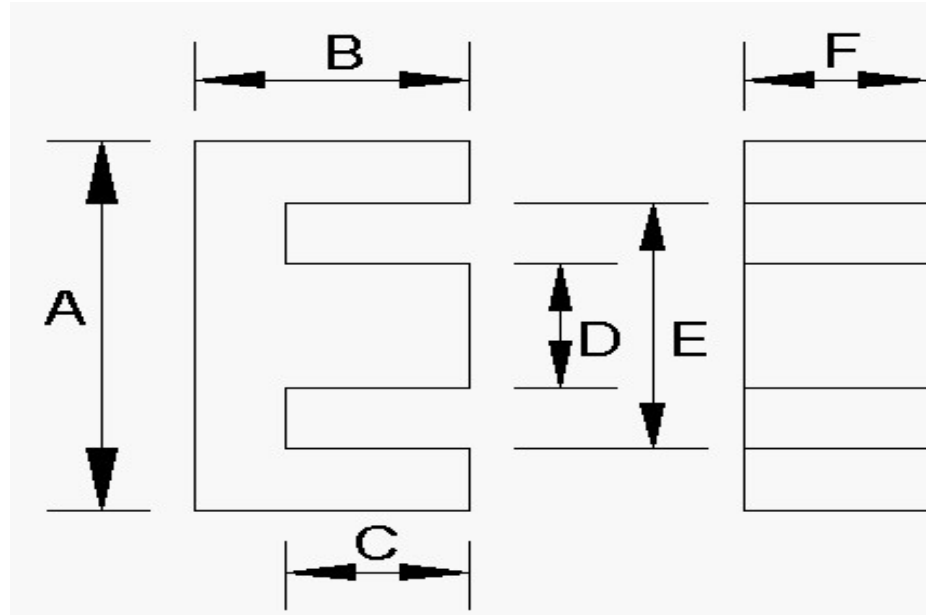

GRIND SPECS	B	C	BW	GRIND BACKWALL	GRIND MATING SURFACE	GAP DEPTH per pc. (inches)	AL VALUE nH/T^2	L CONTROL LIMIT mH
	inches	inches	inches					
Maximum	0.3970	0.2880				0.0000	93.5	0.91225
Nominal	0.3900	0.2830		NO	YES	0.0124	89.0	0.89000
Minimum	0.3830	0.2780				0.0000	84.6	0.86775

Inductance (AL) Test Conditions mate with: **0**

Critical Spec. Al or Mech.	Tolerance	1 or 2 core GAP	Coil #	# Turns	Test Frequency	Test Voltage	Test Flux Density
					kHz	Vrms	Gauss
AL	5%	TWO	385	100	10	0.070	5

Dimensions:	A	D	E	F	G	H	J	COLOR CODE
	inches	inches	inches	inches	inches	inches	inches	
Maximum	0.803	0.229	0.577	0.219				
Nominal	0.787	0.224	0.566	0.214				0
Minimum	0.771	0.219	0.555	0.209				