

UPDATING

UPDATING

UPDATING

UPDATING

UPDATING

UPDATING

Finishing Spec Core

Catalog No. **7070-19-08-05-0117**
190805 E

Picture

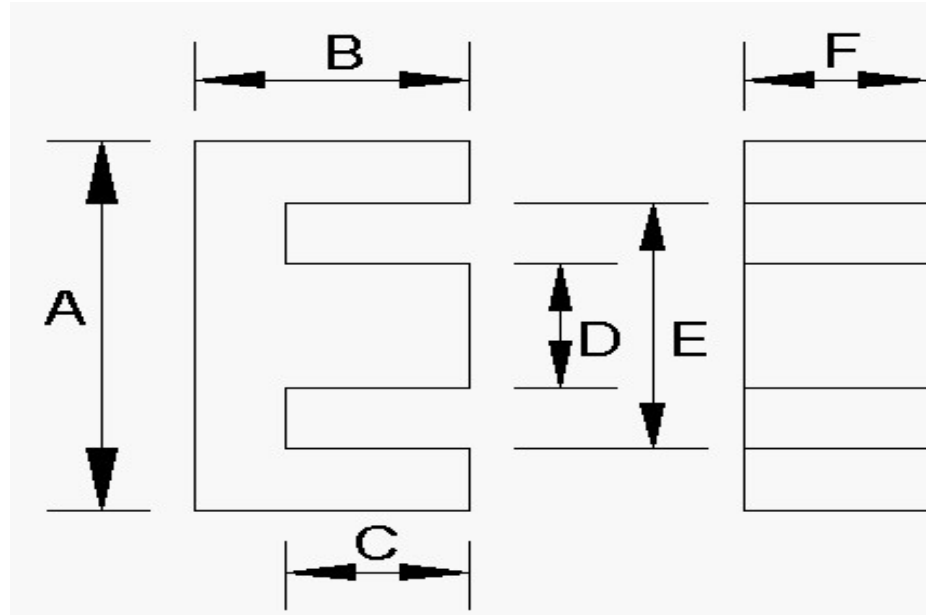

GRIND SPECS	B	C	BW	GRIND BACKWALL	GRIND MATING SURFACE	GAP DEPTH per pc. (inches)	AL VALUE	L CONTROL LIMIT
	inches	inches	inches				nH/T^2	mH
Maximum	0.3220	0.2290					63.4	0.02489
Nominal	0.3170	0.2240		NO	YES	0.0134	61.0	0.02440
Minimum	0.3120	0.2190					58.6	0.02391

Inductance (AL) Test Conditions mate with:

Critical Spec. Al or Mech.	Tolerance	1 or 2 core GAP	Coil #	# Turns	Test Frequency	Test Voltage	Test Flux Density
					kHz	Vrms	Gauss
AL	4%	TWO	5	20	100	0.100	5

Dimensions:	A	D	E	F	G	H	J	COLOR CODE
	inches	inches	inches	inches	inches	inches	inches	
Maximum	0.765	0.191	0.575	0.191				
Nominal	0.750	0.187	0.564	0.187				
Minimum	0.735	0.183	0.553	0.183				