

UPDATING

UPDATING

UPDATING

UPDATING

UPDATING

UPDATING

**Finishing Spec Core**

Catalog No. **7070-16-08-05-0016**  
**160805 E**

Picture

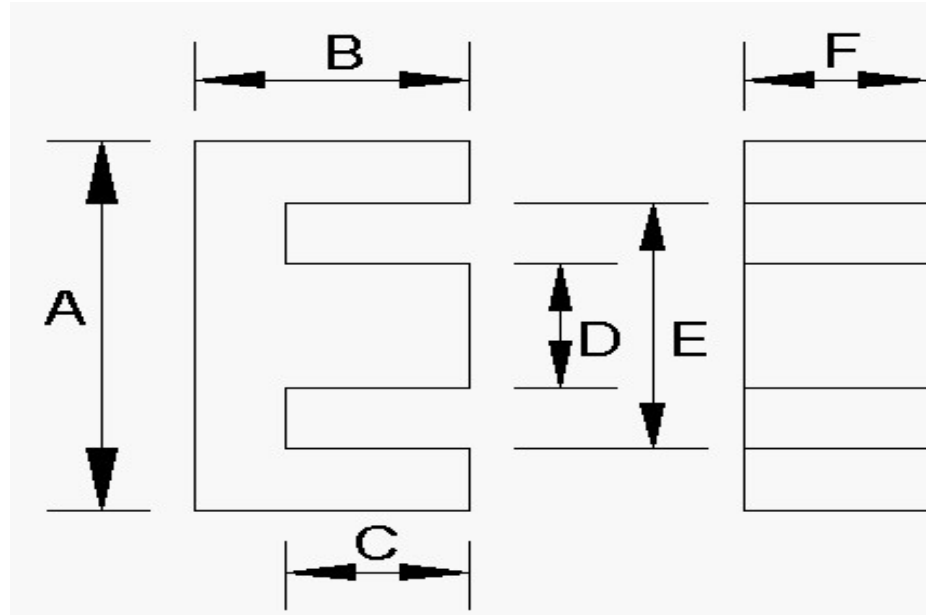

GRIND SPECS	B	C	BW	GRIND BACKWALL	GRIND MATING SURFACE	GAP DEPTH per pc. (inches)	AL VALUE	L CONTROL LIMIT
	inches	inches	inches				nH/T^2	mH
Maximum	0.3220	0.2390					163.5	0.06270
Nominal	0.3170	0.2320		NO	YES	0.0073	150.0	0.06000
Minimum	0.3120	0.2250					136.5	0.05730

Inductance (AL) Test Conditions mate with:

Critical Spec. AI or Mech.	Tolerance	1 or 2 core GAP	Coil #	# Turns	Test Frequency	Test Voltage	Test Flux Density
					kHz	Vrms	Gauss
AL	9%	ONE	532	20	100	0.090	5

Dimensions:	A	D	E	F	G	H	J	COLOR CODE
	inches	inches	inches	inches	inches	inches	inches	
Maximum	0.647	0.183	0.469	0.181				
Nominal	0.634	0.179	0.460	0.177				
Minimum	0.621	0.175	0.451	0.173				